

Data exchange model and software interoperability to improve the energy efficient building design process

Pongsak Chaisuparamikul, Center for Sustainable Cities, College of Architecture and Design, University of Kentucky.

REPORT

INTRODUCTION

Tall building consumes the significant amount of energy, account for a major portion of annual total energy use, electricity consumption, greenhouse gas emissions, raw materials use, waste output and potable water consumption. This research project is motivated and inspired by the current design and practice that the route to achieve energy efficient building and sustainable design from initiative through construction and development of a building life cycle can be very challenging and involved with many actors, required many collaboration, from many different disciplines, all with their own working methods. This research, which is one of my three established integrated model frameworks called Data Modeling Language (VDML), is intended to create data exchange model for energy efficient building information system to improve the building energy efficient design process of tall buildings that have a major impact on the sustainable design and environment, and more ultimately, enabling design professionals to have better informed design decisions. This research focuses on the data exchange model, which provided bidirectional information sharing, data reuse capabilities, and software interoperability, which provided data exchange modeling and mapping between the model and energy through Virtual Model Environment (VME) framework and Virtual Model System (VMS).

KEY FINDINGS

- From the preliminary research results indicated that the hypotheses and assumptions about software interoperability in support of work processes for a significant part of a building's life cycle can provide common attributes and data structure of shared objects in various domains for modeling.
- The smart digital contents or BIM models, which have the capabilities to store data in both instance and building type parameters, and can inherit or refer to other object model in other class. The geometry for the Dial-grid and curtain wall of this super tower is comprised of a complex set of calculated coordinates. These coordinates have been built into the illustrated shapes using a number of parameters. The parameters in this example allow the shape of the curtain wall and Dial-grid structure to be transformed as the unit placed throughout the project.
- Data mapping engine in Virtual Model Environment (VME) framework and Virtual Model System (VMS) Application Program Interface (API) provided graphically and data mapped relationships and hierarchical structure among these smart BIM models. Application Server has been developed to accomplish the task of fully converting this smart building information model to energy performance model.
- Developed database to retrieve and query the data that has been extracted through VMS A.P.I., performed data mapping and organized data relationship. Database ranged from a single data table in the dataset to entities relationship database of information model, and provided functionality for connecting to a data source in VME Framework, executing commands, and retrieving results.

METHODOLOGY

This research proposes to create data exchange building information model (BIM) and software interoperability using ongoing conceptual design stages of a 111 stories, 275,000 square meters, 583 meters high, mixed-use tower high-rise project. VME Framework Application Program Interface implemented the operation of the smart BIM objects/models by using the new operator, which is a method to send, receive, or cast data between smart BIM models and energy simulation program. Figure 1 illustrates by providing ongoing framework and set of tools in acquiring information from building geometries, coordinates, climate location, thermal zones and surfaces, construction and materials properties etc. VME Framework enabled the most efficient interoperability of information model between Autodesk Revit and DOE2.

- VME framework used basic terminology and concepts such as tags, schemas, database, and transforms to perform data exchange, data mapping, data retrieval, and data binding. VMS extracted in and out of building geometries, graphical and attribute, coordinates, parameters, properties, materials, schedules, system and equipments from the smart objects/models, and provided a modular structure to the smart BIM model framework for sharing

information through VMS application program interface (A.P.I.)

- Virtual Model System (VMS) used the framework from VME to extract information from smart BIM models through A.P.I., created data systems design to hold the elements, geometric and parametric and store data in the database to enable information, model components to be reused.
- VMS Queried the data and created energy input data file format and parameters for simulation as designated in the namespaces such as geometries, collected data of the building elements, geometries, coordinate, location, orientation, area, thermal zones and surfaces, and space. This process allowed the reusability of building components or parts as a BIM library that can be called from multiple areas of the applications. Database retrieves and queries information that has been extract through API
- Simulated the energy input using DOE 2 engine and eQuest.
- Created and displayed energy simulation results reports, images, graphs and charts through a VMS application user interface (A.U.I.). This software interface, which runs on the web browser, displayed and disseminated building's energy performance on the internet.

Conclusion

Virtual Model Environment Framework (VME) and Virtual Model System (VMS) is enabling technologies that provide software interoperability through shared information models and data modeling. VME and VMS updating, and reusing were reviewed. The innovative specifications and ability to link and share object-based model in BIM with performance-based model in energy simulation were introduced. The benefits of adopting VME Framework and VMS are the significant reduced time and effort spent in creating energy efficient building and sustainable design. A data model can be expanded to any other CAD application and energy simulation software.

This research aimed to present an innovative framework, tool and system that map between building information models, using Autodesk Revit Architecture and Building System with thermal simulation software using DOE-2 Using data modeling and application program Interface (A.P.I.) framework specifications for mapping data of building geometry, thermal zone, construction and material properties, and thermal design parameters, were discussed. A data mapping engine in VME Framework Server has been developed to accomplish the task of fully converting building information model to energy performance model. Data work flow and the implementation of model mapping were presented, and the process of data mapping was demonstrated with the illustrative examples.

DATA EXCHANGE MODEL AND SOFTWARE INTEROPERABILITY TO IMPROVE THE ENERGY EFFICIENT BUILDING DESIGN PROCESS

PONGSAK CHAISUPARASMIKUL, CENTER FOR SUSTAINABLE CITIES, COLLEGE OF ARCHITECTURE AND DESIGN, UNIVERSITY OF KENTUCKY.

- Data mapping engine in Virtual Model Environment (VME) framework and Virtual Model System (VMS) Application Program Interface (API) provided graphically and data mapped relationships and hierarchical structure among these smart BIM models. Application Server has been developed to accomplish the task of fully converting this smart building information model to energy performance model.
- Developed database to retrieve and query the data that has been extracted through VMS A.P.I., performed data mapping and organized data relationship. Database ranged from a single data table in the dataset to entities relationship database of information model, and provided functionality for connecting to a data source in VME Framework, executing commands, and retrieving results.

METHODOLOGY

This research proposes to create data exchange building information model (BIM) and software interoperability using ongoing conceptual design stages of a 111 stories, 275,000 square meters, 583 meters high, mixed-use tower high-rise project. Figure 1 illustrates by providing ongoing framework and set of tools in acquiring information from building geometries, coordinates, climate location, thermal zones and surfaces, construction and materials properties etc. VME Framework enabled the most efficient interoperability of information model between Autodesk Revit and DOE2.

- VME framework used basic terminology and concepts such as tags, schemas, database, and transforms to perform data exchange, data mapping, data retrieval, and data binding. VMS extracted

in and out of building geometries, graphical and attribute, coordinates, parameters, properties, materials, schedules, system and equipments from the smart objects/models, and provided a modular structure to the smart BIM model framework for sharing information through VMS application program interface (A.P.I.)

- Virtual Model System (VMS) used the framework from VME to extract information from smart BIM models through A.P.I., created data systems design to hold the elements, geometric and parametric and store data in the database to enable information, model components to be reused.
- VMS Queried the data and created energy input data file format and parameters for simulation as designated in the namespaces such as geometries, collected data of the building elements, geometries, coordinate, location, orientation, area, thermal zones and surfaces, and space. This process allowed the reusability of building components or parts as a BIM library that can be called from multiple areas of the applications. Database retrieves and queries information that has been extract through API
- Simulated the energy input using DOE 2 engine and eQuest.

ADDENDUM 01

VME Framework Application Program Interface implemented the operation of the smart BIM objects/models by using the new operator, which is a method to send, receive, or cast data between smart BIM models and energy simulation program.

- Smart digital contents or BIM models have the capabilities to store data in both instance and building type parameters, and can inherit or refer to other object model in other class.

MEP Smart Objects and Contents Checklist

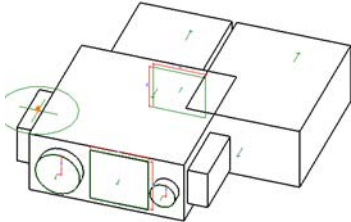
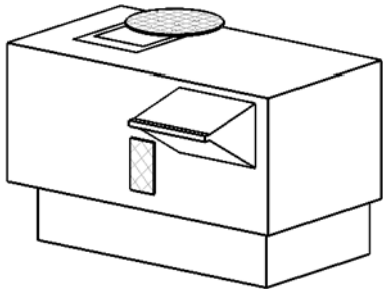
<i>Contents</i>	<i>Images</i>
<ul style="list-style-type: none"> • <i>Air Side</i> 	
<ul style="list-style-type: none"> • <i>Roof top Air Conditoners Unit_Electrical</i> 	
<ul style="list-style-type: none"> ... <i>Roof top Air Conditoners 3.0 -12.5 tons</i> 	
<ul style="list-style-type: none"> • <i>Roof top Air Conditoners Unit_Gas</i> 	
<ul style="list-style-type: none"> ... <i>Roof top Air Conditoners 3.0 -12.5 tons</i> 	

... Air Handling Unit

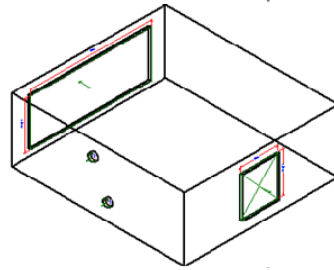

• Air Side

... Rectangular duct takeoff

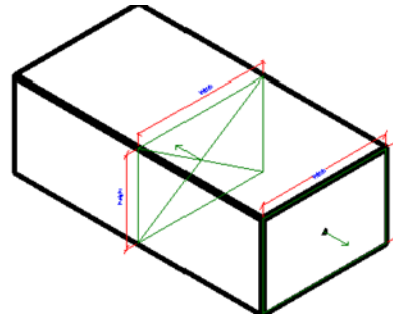

... Rectangular to round duct transition

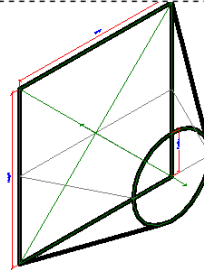

... Rectangular to round duct transition

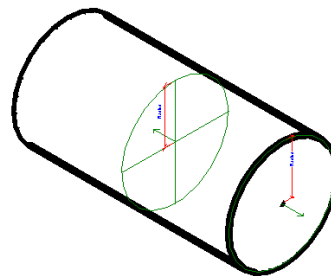

CASE STUDY

For a high-rise a 111 stories, 275,000 square meters, 583 meters high, mixed-use tower high-rise project. VME Framework Application Program Interface implemented the operation of the smart BIM objects/models by using the new operator, which is a method to send, receive, or cast data between smart BIM models and energy simulation program.

The geometry for the dial-grid and curtain wall of this super tower is comprised of a complex set of calculated coordinates. These coordinates have been built into the illustrated shapes using a number of parameters. The parameters in this example allow the shape of the curtain wall and dial-grid structure to be transformed as the unit is placed throughout the project.

As shown above, the values for these parameters are generated for the entire project in a scripted environment such as Autocad LiSP/VBA or RhinoScript. Currently, these values must be manually entered into each instance of the loaded family in the Revit project. This R&D proposal seeks to establish a link between a scripting environment or a database of values and placed instances of custom geometry in Revit.

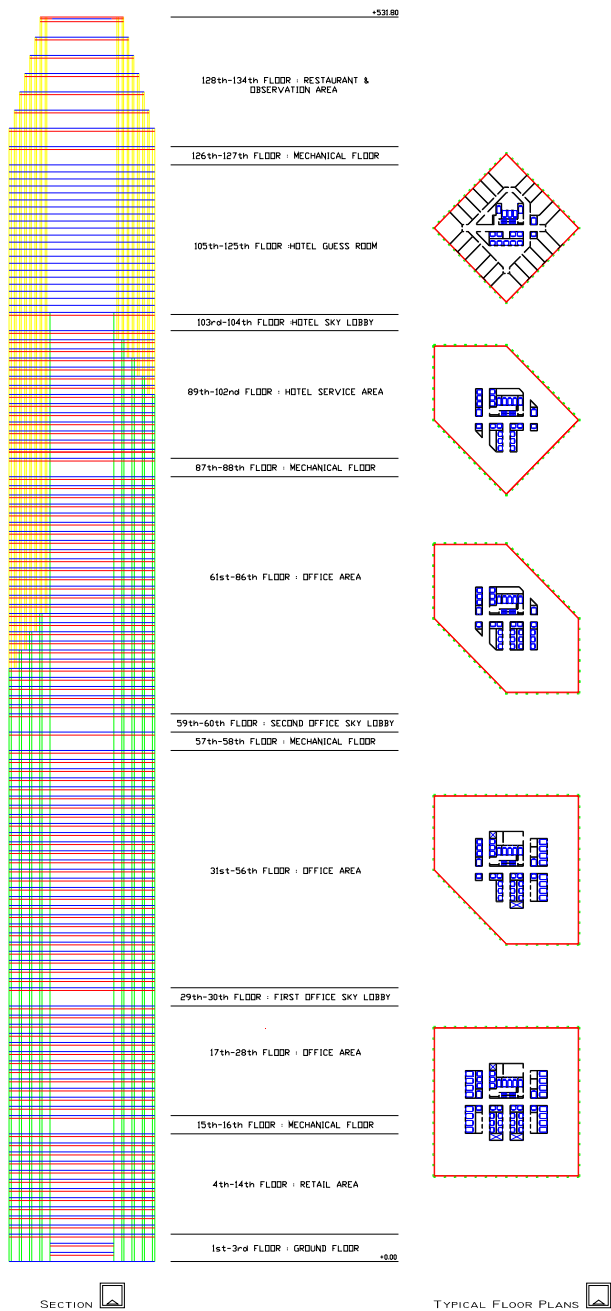

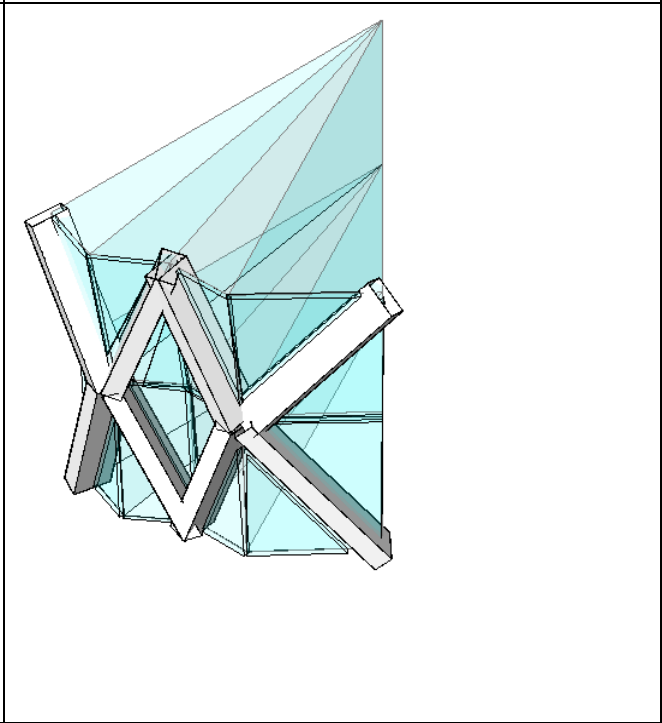
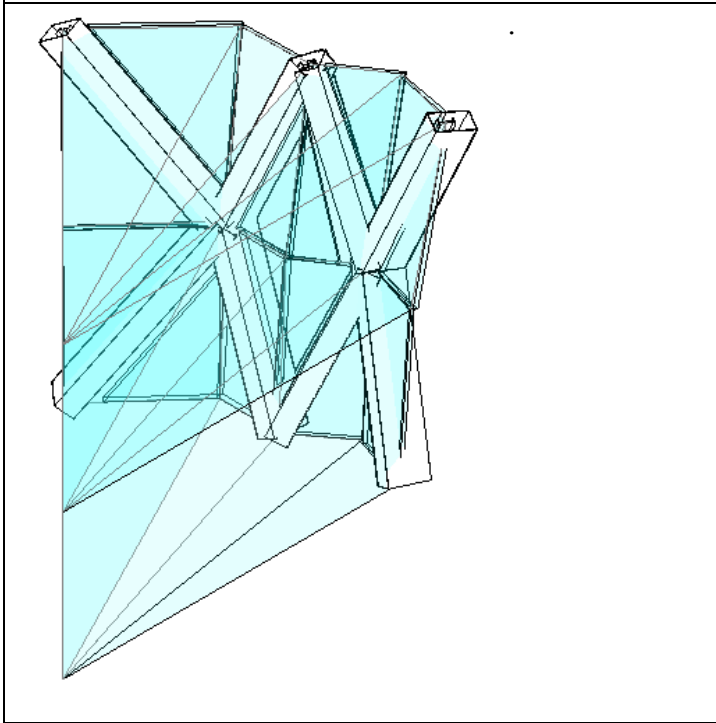
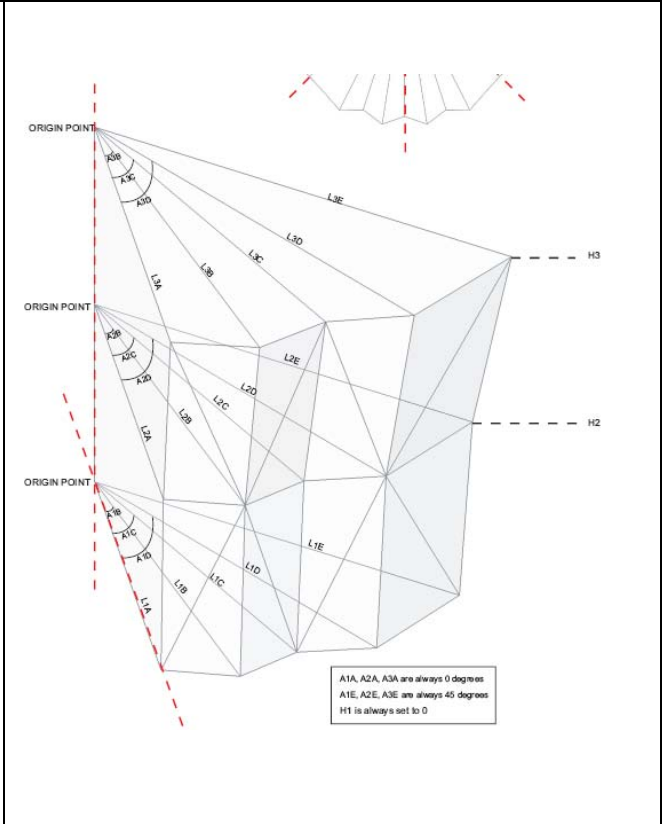
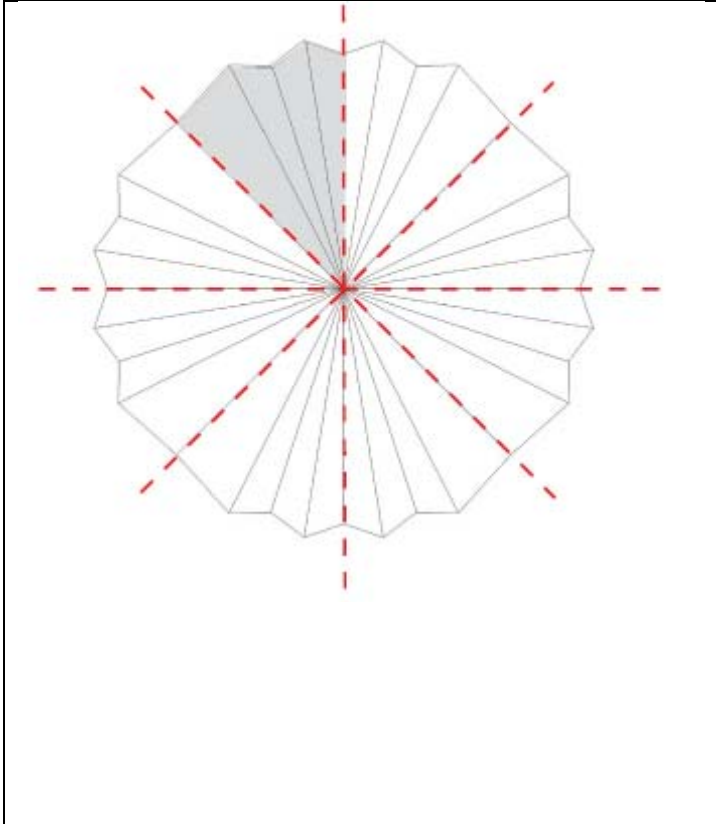

ADDENDUM 03

in acquiring information from building geometries, coordinates, climate location, thermal zones and surfaces, construction and materials properties etc. VME Framework enabled the most efficient interoperability of information model by data extraction.

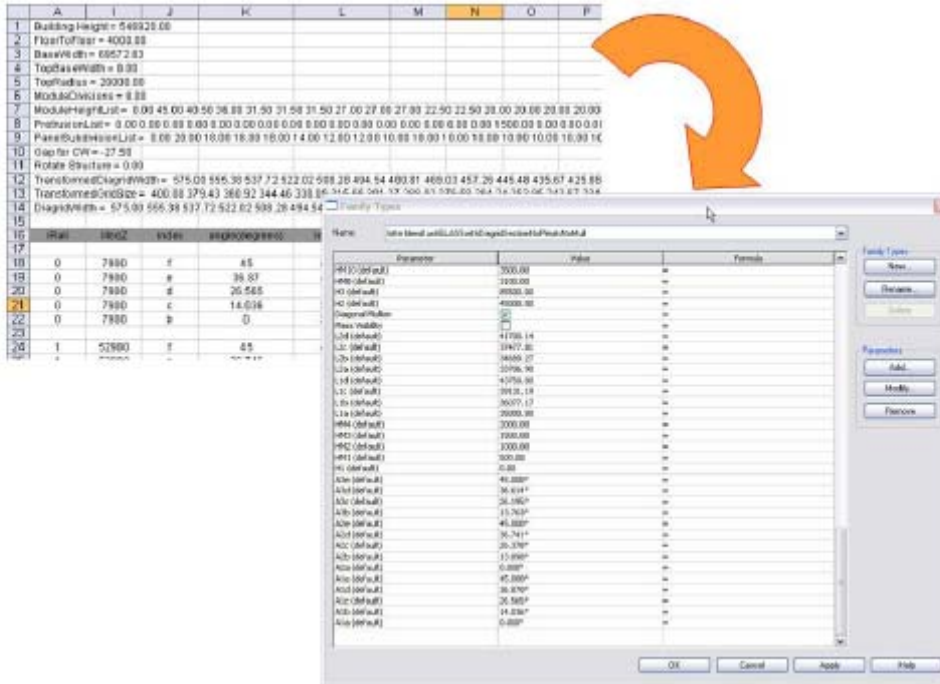

iRail liftedZ index angle(degrees) length(mm)
 0 7900 e 45 49175.29
 0 7900 d 36.87 43465.22
 0 7900 c 26.565 38876.48
 0 7900 b 14.036 35842.34
 0 7900 a 0 34772.18
 1 52900 e 45 41021.31
 1 52900 d 36.752 41450.02
 1 52900 c 26.398 37207.32
 1 52900 b 13.91 34454.81
 1 52900 a 0 33444.42
 2 93400 e 45 44457.98
 2 93400 d 36.64 39579.5
 2 93400 c 26.228 35762.34
 2 93400 b 13.791 33149.16
 2 93400 a 0 32306.51
 2 93400 e 45 44457.98
 2 93400 d 36.64 39579.5
 2 93400 c 26.228 35762.34

2 93400 b 13.791 33149.16
2 93400 a 0 32306.51
3 129400 e 45 37609.29
3 129400 d 36.524 38024.63
3 129400 c 26.076 34370.59
3 129400 b 13.67 32096.43
3 129400 a 0 31187.24
4 160900 e 45 40733.8
4 160900 d 36.425 36512.36
4 160900 c 25.917 33304.82
4 160900 b 13.568 31023.46
4 160900 a 0 30359.94
4 160900 e 45 40733.8
4 160900 d 36.425 36512.36
4 160900 c 25.917 33304.82
4 160900 b 13.568 31023.46
4 160900 a 0 30359.94
5 192400 e 45 34799.4
5 192400 d 36.302 35204.26
5 192400 c 25.768 32035.4
5 192400 b 13.444 30154.72
5 192400 a 0 29328.38
6 223900 e 45 37257.89
6 223900 d 36.188 33650.25
6 223900 c 25.582 31012.17
6 223900 b 13.33 29039.96
6 223900 a 0 28543.13
6 223900 e 45 37257.89
6 223900 d 36.188 33650.25
6 223900 c 25.582 31012.17
6 223900 b 13.33 29039.96
6 223900 a 0 28543.13
7 250900 e 45 32190.21
7 250900 d 36.062 32585.9
7 250900 c 25.439 29867.96
7 250900 b 13.207 28352.17
7 250900 a 0 27602.29
8 277900 e 45 34278.54
8 277900 d 35.95 31197.54
8 277900 c 25.253 29048
8 277900 b 13.099 27340.27
8 277900 a 0 26985.87
8 277900 e 45 34278.54
8 277900 d 35.95 31197.54
8 277900 c 25.253 29048
8 277900 b 13.099 27340.27
8 277900 a 0 26985.87
9 304900 e 45 29781.73
9 304900 d 35.803 30169.54
9 304900 c 25.09 27868.26
9 304900 b 12.959 26688.77
9 304900 a 0 26008.99
10 327400 e 45 31547.47
10 327400 d 35.697 28949.77
10 327400 c 24.91 27248.47
10 327400 b 12.86 25782.66
10 327400 a 0 25558.38
10 327400 e 45 31547.47
10 327400 d 35.697 28949.77
10 327400 c 24.91 27248.47
10 327400 b 12.86 25782.66
10 327400 a 0 25558.38
11 349900 e 45 27774.66
11 349900 d 35.554 28156.45
11 349900 c 24.758 26202.74
11 349900 b 12.728 25303.04
11 349900 a 0 24681.23

12 372400 e 45 29064.68
12 372400 d 35.43 26906.92
12 372400 c 24.557 25613.49
12 372400 b 12.617 24367.09
12 372400 a 0 24260.66
12 372400 e 45 29064.68
12 372400 d 35.43 26906.92
12 372400 c 24.557 25613.49
12 372400 b 12.617 24367.09
12 372400 a 0 24260.66
13 392400 e 45 25879.1
13 392400 d 35.283 26255.76
13 392400 c 24.404 24630.65
13 392400 b 12.486 23994.7
13 392400 a 0 23427.24
14 412400 e 45 26857.76
14 412400 d 35.157 25091.61
14 412400 c 24.202 24161.1
14 412400 b 12.375 23109.22
14 412400 a 0 23107.13
14 412400 e 45 26857.76
14 412400 d 35.157 25091.61
14 412400 c 24.202 24161.1
14 412400 b 12.375 23109.22
14 412400 a 0 23107.13
15 432400 e 45 24095.04
15 432400 d 34.99 24467.49
15 432400 c 24.027 23152.02
15 432400 b 12.232 22763.77
15 432400 a 0 22247.01
16 452400 e 45 24650.83
16 452400 d 35.72 21817.35
16 452400 c 23.802 22709.76
16 452400 b 12.452 20357.22
16 452400 a 0 21953.61
16 452400 e 45 24650.83
16 452400 d 35.72 21817.35
16 452400 c 23.802 22709.76
16 452400 b 12.452 20357.22
16 452400 a 0 21953.61
17 468400 e 45 22489.38
17 468400 d 34.687 22858.68
17 468400 c 23.643 21822.22
17 468400 b 11.978 21656.35
17 468400 a 0 21184.8
18 484400 e 45 22885.29
18 484400 d 34.55 21825.84
18 484400 c 23.443 21549.57
18 484400 b 11.867 20846.25
18 484400 a 0 21030.78
18 484400 e 45 22885.29
18 484400 d 34.55 21825.84
18 484400 c 23.443 21549.57
18 484400 b 11.867 20846.25
18 484400 a 0 21030.78
19 500400 e 45 21062.13
19 500400 d 34.379 21429.24
19 500400 c 23.261 20641.1
19 500400 b 11.731 20672.37
19 500400 a 0 20240.62
20 514400 e 45 21230.1
20 514400 d 34.239 20465.98
20 514400 c 23.07 20462.75
20 514400 b 11.621 19903.92
20 514400 a 0 20165.64
20 514400 e 45 21230.1
20 514400 d 34.239 20465.98

20 514400 c 23.07 20462.75
20 514400 b 11.621 19903.92
20 514400 a 0 20165.64
21 526400 e 45 19902.5
21 526400 d 34.097 20268.33
21 526400 c 22.917 19682.19
21 526400 b 11.511 19873.2
21 526400 a 0 19473.47
22 536900 e 45 19988.7
22 536900 d 33.978 19446.54
22 536900 c 22.763 19648.26
22 536900 b 11.42 19197.42
22 536900 a 0 19516.78
22 536900 e 45 19988.7
22 536900 d 33.978 19446.54
22 536900 c 22.763 19648.26
22 536900 b 11.42 19197.42
22 536900 a 0 19516.78
23 546500 e 45 19006
23 546500 d 33.856 19371.23
23 546500 c 22.627 18941.4
23 546500 b 11.329 19255.59
23 546500 a 0 18880.41
24 554820 e 45 19000
24 554820 d 33.75 18634.92
24 554820 c 22.5 19000
24 554820 b 11.25 18634.92
24 554820 a 0 19000

ADDENDUM 04

SYSTEM SELECTION FOR EACH ZONE

		# of	Ftr	Qty	Hr	Ftr	Gross	Ftr	Expos	Wdr	CLATING	System	
or	Levels	Ftr	H'	H'	L'	W'	Area/Ftr	L'/Ftr	Area/Ftr	H'	V	AC	T
chemical	B0	1	20	10	720	200	41,000	1,010	20,000	n			BOV
mat. Poly	B0, B1	2	10	0	720	200	41,000	1,010	10,000	n			WASH
off/lobby	L1	1	20	17	200	100	41,000	000	17,000				VAVS ?
all	L2-L3	2	13	11	200	100	41,000	000	13,000				WHP ?
hang Flu	L4-L7	4	10	0	200	100	41,000	000	0pm	n			n
chemical	L8	1	20	10	200	100	41,000	000	17,000	n			BOV
ice	L9-L20	12	13	10	220	120	24,400	000	0,000				VAVS + FHW
chemical	L20	1	20	10	220	120	24,400	000	13,000	n			BOV
Fluor	L20-L20	4	13	11	220	120	24,400	000	10,000				VAVS ?
oil Flu	L20-L20	10	10	0	100	120	10,000	300	3,000				4P-FCU
oil Flu	L20-L20	3	10	0	100	120	10,000	300	3,000				PTAC
incubator	L20	1	13	10	100	120	10,000	300	0,000				VAVS ?
chemical	L20	1	20	10	100	100	14,000	300	10,000	n			BOV

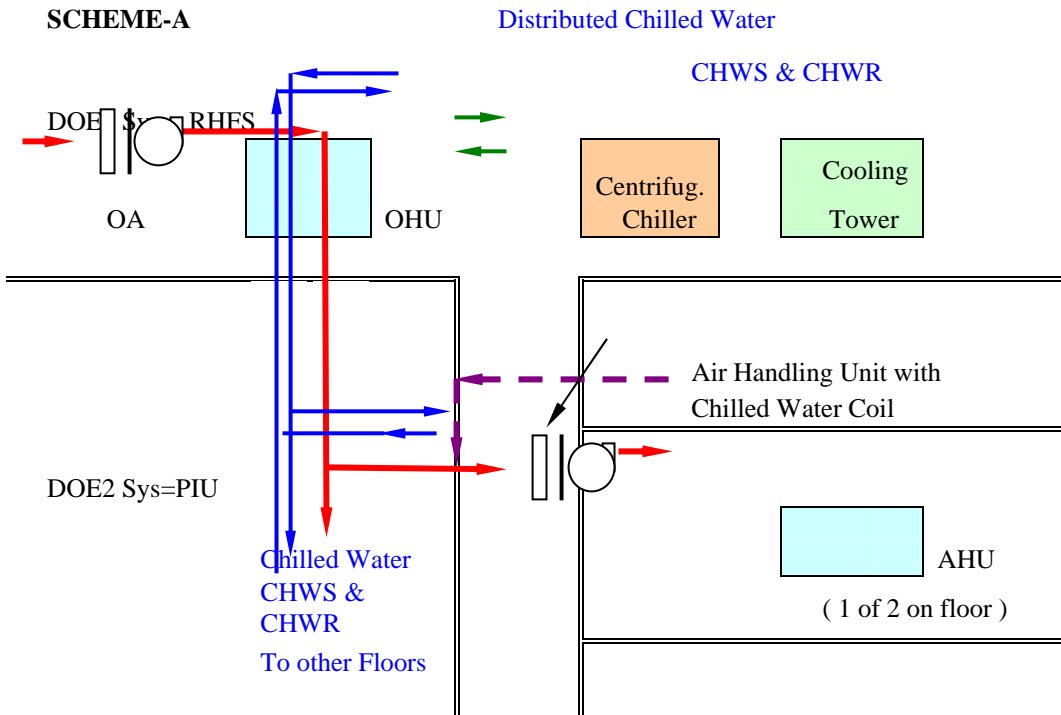

SCHEME-B

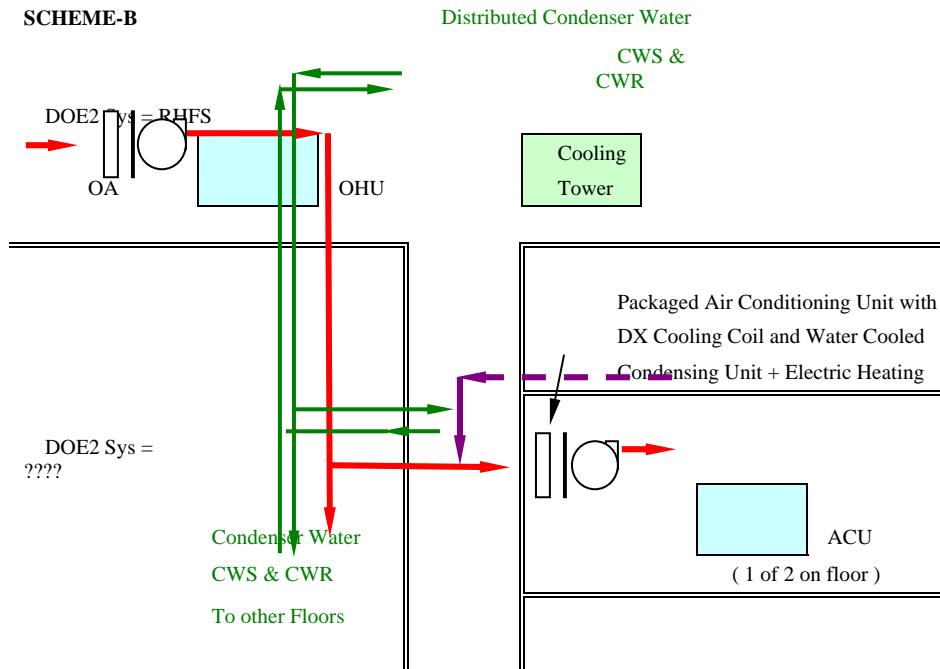

SCHEME-C

Central AHU System

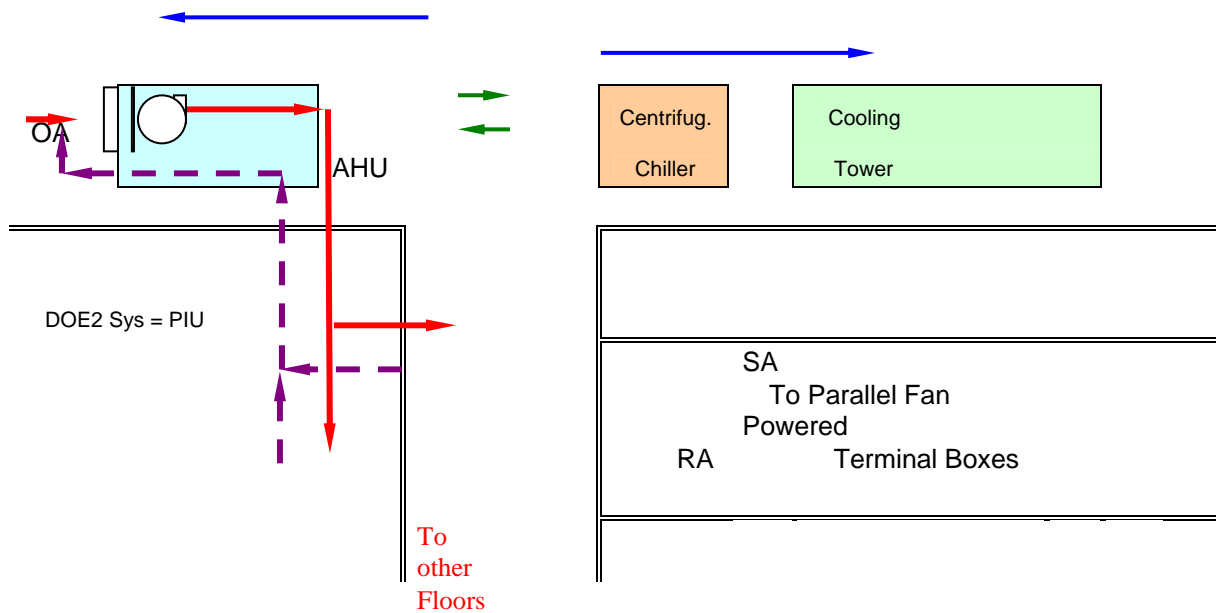

OA AIR SYSTEM for SCHEMES A and B

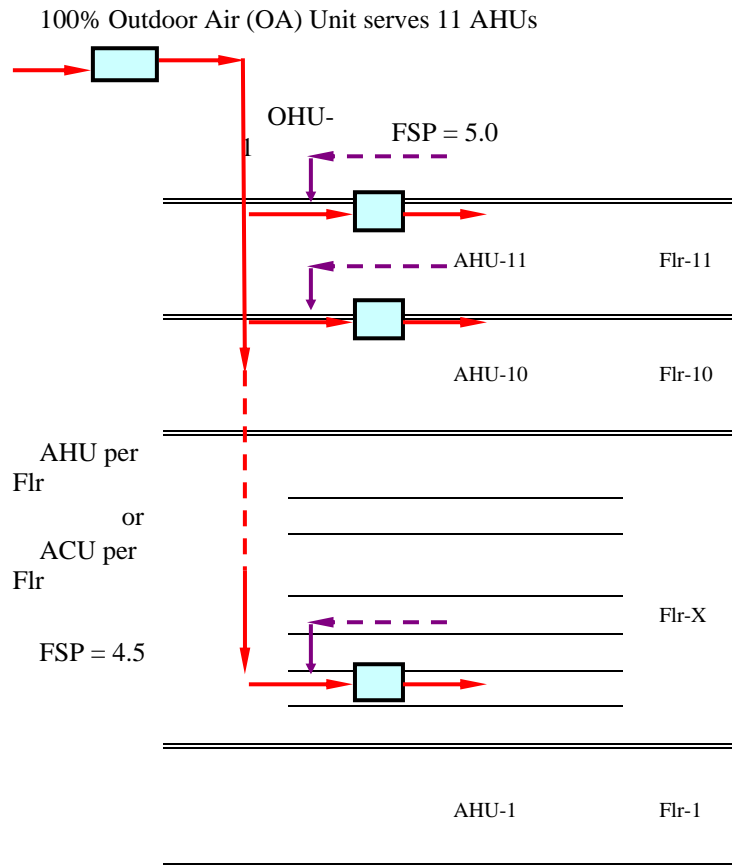

- Created and displayed energy simulation, results reports, images, graphs and charts through a VMS application user interface (A.U.I.). This software interface, which runs on the web browser, displayed and disseminated building's energy performance on the internet.

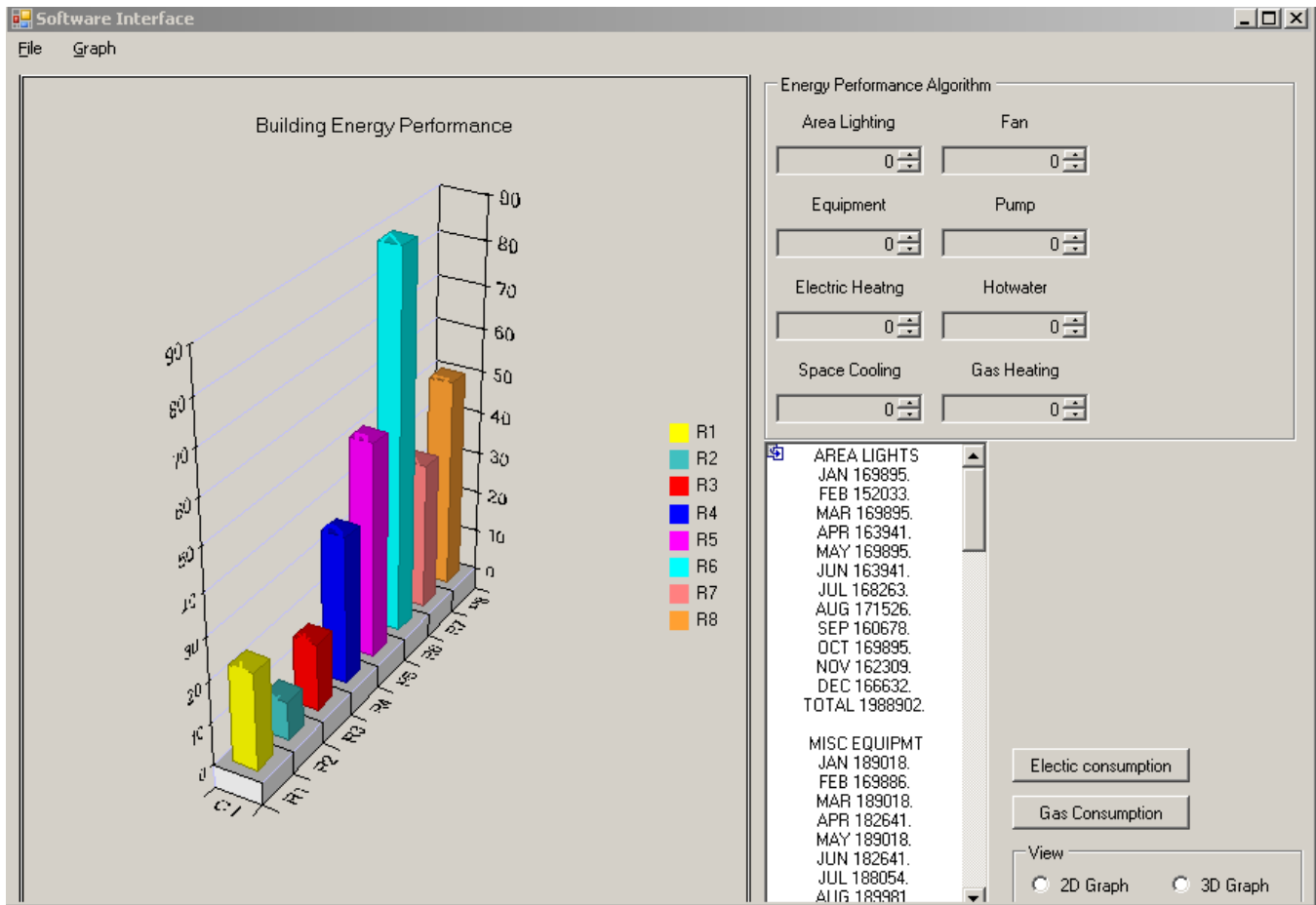

Future Work

The followings are the next phases of my research;

- Preparing, designing, programming and prototyping the digital contents or BIM objects that represent all of the building components and system of plan, model, drawings and construction documents using Autodesk Revit Architecture and MEP 2008 and AutoCAD 2008. This BIM objects/models have the ability to link both graphical and numerical data and coordinate every building element in one database, thus providing users the ability to immediately see the results of any design revisions made in the model, have them reflected in the associated views (drawings), as well as to detect any coordination issues.
- Created the software interface, which displayed energy simulation results reports, images, graphs and charts through a VMS application user interface (A.U.I.). This software interface which runs on the web browser, displayed and disseminated building's energy performance on the internet.